

## Orbital sander pistol, Ø 3"

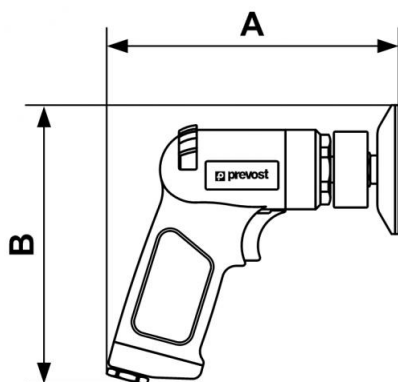

<b><u>Offset (mm)</u></b> 3	<b><u>Diameter (plate)</u></b> 75 mm 3"	<b><u>Consumption (l/min)</u></b> 113	<b><u>Power (CV - W)</u></b> 0.45 CV - 330 W
<b><u>Rotation speed (rpm)</u></b> 16 000	<b><u>BSPT female thread</u></b> R 1/4	<b><u>Sound level (dB(A))</u></b> 80	<b><u>Weight (kg)</u></b> 0.72
<b><u>Max operating pressure</u></b> 6,2 bar	<b><u>Applications</u></b> Stripping and preparation prior to painting	<b><u>Highlight</u></b> Easy to use and low sound level	<b><u>Connection</u></b> Supplied with 3 adaptors: ISO 6150 B; European 7,4 mm; ARO 210

Description								
Reference	Offset (mm)	Diameter (plate)	Consumption (l/min)	Power (CV - W)	Rotation speed (rpm)	BSPT female thread	Sound level (dB(A))	Weight (kg)
<b>TPS E16000</b>	3	75 mm 3"	113	0.45 CV - 330 W	16 000	R 1/4	80	0.72



### Dimensions

Reference	A mm	B mm
<b>TPS E16000</b>	165	158