

DGO series - Twin-line welding hoses without safety coupler

ISOFLAM



<p><u>ID/OD (mm)</u></p> <p>10 x 17</p>	<p><u>Length (m)</u></p> <p>15</p>	<p><u>Technology</u></p> <p>Pipe locked with ratchet stop</p>	<p><u>Max operating pressure</u></p> <p>Oxygen : 1,5 bar Acetylene : 12,5 bar</p>
<p><u>Construction</u></p> <p>Epoxy-coated steel case</p>	<p><u>Applications</u></p> <p>Welding, cutting</p>	<p><u>Connection</u></p> <p>1 m of inlet supply hose</p>	<p><u>Equipped with</u></p> <p>Fixed bracket</p>

Description		
Reference	ID/OD (mm)	Length (m)
DGO 10150A	10 x 17	15

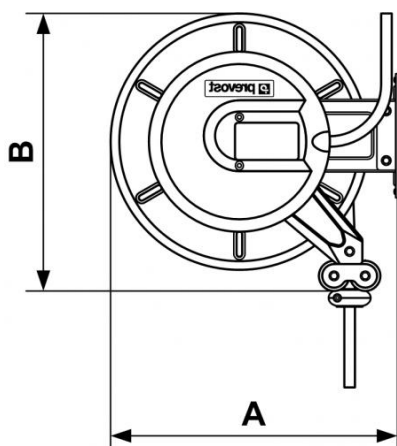

Dimensions

Reference	A mm	B mm
DGO 10150A	460	447